

CITROËN



NEW CITROËN È-RELAY & RELAY

Prices & Specifications

nothing
moves us
like Citroën

Effective from 1 June 2024 – MY24

[f](#) [t](#) [i](#) [v](#) FOLLOW US

[✉](#) ENQUIRY

[🚗](#) TEST DRIVE

[➔](#) ENHANCED ONLINE PRICES & SPECS

NEW CITROËN Ę-RELAY & RELAY

Uncompromised comfort



Discover New Citroën Ę-Relay Electric and Citroën Relay, and experience the same robustness and comfort in either electric or diesel, panel van, window van or Relay conversion.

A resolutely modern design expressing dynamism and strength feature headlights equipped with LED daytime running lights to complete a stylish front end. But it's the remarkable choice of load capacity and body type that sets Citroën Relay apart to meet the exact needs of your business.

Model trim

Panel/Window Van

È-Relay Enterprise models include:

Comfort and convenience

Automatic air-conditioning for cab area

Rear parking sensors

Electric front windows

Twin lens door mirrors with electrically adjustable and heated upper mirror

Two cup holders and mobile phone storage in centre of lower dashboard

Electric Parking Brake

Keyless Entry and Go

Electric Power Steering

Exterior features

Side rubbing strips

Steel wheels with centre cap

Twin unglazed rear doors (opening to 180° - panel van only)

Nearside sliding side loading door

Twin glazed rear doors with heated windows (opening to 180° - window van only)

Glazing to row 2, 3, and nearside sliding side loading door (window van only)

Aerodynamic kit: Central Spoiler, Air Guides and Active Grille Shutter

Seating

Driver's seat with height, rake, lumbar and reach adjustment

Driver's seat armrest

Dual Passenger bench seat

Safety and security

Full steel bulkhead

Electronic Stability Control (ESC)

Driver's and double passenger airbags

Perimetric alarm and deadlocks

Fix and go kit

Rear visibility camera with dynamic gridlines

Tyre Pressure Monitoring System (TPMS)

Advanced Emergency Braking System (AEBS) - Pedestrian and Cyclist

Lane Support System

Traffic Sign Recognition

Driver Drowsiness Detection

Intelligent Speed Assist

Global Telematics Box

Citroën Connect Box with Emergency and Assistance system



NEW CITROËN Ę-RELAY & RELAY

Prices

Trim	Length/Height	ELECTRIC	Maximum indicative payload (kg)	Load space (m³)	Gross Vehicle Weight (kg)	WLTP CO ₂ g/km*	LCDV Codes	Basic MRRP†	Government grant^	Basic price after PiVG
Panel Van Enterprise	L3H2	Ę-Relay Panel Van L3H2 35 110kWh Enterprise	635	13	3500	0	2CXE3FHOKKU0A010	£49,485	£5,000	£44,485
	L3H2	Ę-Relay Panel Van L3H2 40 110kWh Enterprise	1385	13	4000	0	2CXE5MHYAFU0A010	£50,295	£5,000	£45,295
	L3H3	Ę-Relay Panel Van L3H3 40 110kWh Enterprise	1360	15	4000	0	2CXE5PHYAFU0A010	£51,105	£5,000	£46,105
	L4H2	Ę-Relay Panel Van L4H2 40 110kWh Enterprise	1340	15	4000	0	2CXE7MHYAFU0A010	£51,105	£5,000	£46,105
	L4H3	Ę-Relay Panel Van L4H3 40 110kWh Enterprise	1310	17	4000	0	2CXE7PHYAFU0A010	£51,915	£5,000	£46,915
Window Van Enterprise	L4H2	Ę-Relay Window Van L4H2 40 110kWh Enterprise	1340	15	4000	0	2CXE7YHYAFU0A010	£51,555	£5,000	£46,555
Chassis Cab Enterprise	L3H1	Ę-Relay Chassis Cab L3H1 40 110kWh Enterprise	1695	-	4000	0	2CXE6HHYAFU0A010	£47,865	£5,000	£42,865



All information and prices correct at time of publication, but are subject to change at any time without prior notice (which may occur as a result of matters including, but not limited to, any changes in legislation and/or any changes by the government). Please see our Prices and Specifications brochures or contact your local Citroën Retailer for the most up-to-date prices and specification details for all models. CO₂ figures above are for a standard vehicle without any additional optional equipment. The addition of optional extras could increase the certified CO₂ emission output.

* WLTP figures shown are for comparison purposes and should only be compared to the fuel consumption and CO₂ values of other vans tested to the same technical standard. The fuel consumption achieved, and CO₂ produced, in real world conditions will depend upon a number of factors including, but not limited to: the accessories fitted (pre and post registration); variations in weather; driving styles and vehicle load. The WLTP (Worldwide Harmonised Light Vehicles Test Procedure) is used to measure fuel consumption and CO₂ figures.

† All Manufacturer's Recommended Basic Prices are exclusive of V.A.T., Delivery to Retailer and Number Plates, Government First Registration Fee and Vehicle Excise Duty.

^ The Government PiVG is worked out at 35% of the Base Vehicle Price (incl. VAT) and including any discounts applied up to a maximum of £5,000.

Legal notice ELECTRIC VEHICLES:

The range and electric consumption figures mentioned comply with the WLTP test procedure, on the basis of which new vehicles are type approved from 1 September 2018. They may vary depending on actual conditions of use and on different factors such as: speed, thermal comfort on board the vehicle, driving style and outside temperature. The charging time depends in particular on the power of the charger on board the vehicle, the charging cable and the type and power of the charging station used.

NEW CITROËN E-RELAY & RELAY

Prices

Trim	Length/Height	ICE	Maximum indicative payload (kg)	Load space (m ³)	Gross Vehicle Weight (kg)	WLTP CO ₂ g/km*	LCDV Code	Basic MRRP†
Panel Van Enterprise	L2H1	Relay Panel Van L2H1 35 BlueHDi 140 S&S 6-speed Manual Enterprise	1425	10	3500	198-216	2CXE3FHOKKU0A010	£30,615
	L2H2	Relay Panel Van L2H2 35 BlueHDi 140 S&S 6-speed Manual Enterprise	1400	11.5	3500	205-231	2CXE3KHOKKU0A010	£31,425
	L2H2	Relay Panel Van L2H2 35 BlueHDi 140 S&S EAT8 Auto Enterprise	1340	11.5	3500	226-255	2CXE3KHOK1U0A010	£33,525
	L3H2	Relay Panel Van L3H2 35 BlueHDi 140 S&S 6-speed Manual Enterprise	1350	13	3500	205-231	2CXE5KHOKKU0A010	£32,235
	L3H2	Relay Panel Van L3H2 35 BlueHDi 140 S&S EAT8 Auto Enterprise	1290	13	3500	226-255	2CXE5KHOK1U0A010	£34,335
	L3H3	Relay Panel Van L3H3 35 BlueHDi 140 S&S 6-speed Manual Enterprise	1325	15	3500	217-239	2CXE5NHOKKU0A010	£33,045
	L3H2	Relay Panel Van L3H2 35 Heavy BlueHDi 140 S&S 6-speed Manual Enterprise	1310	13	3500	205-231	2CXE5LHOKKU0A010	£32,685
	L4H2	Relay Panel Van L4H2 35 Heavy BlueHDi 140 S&S 6-speed Manual Enterprise	1265	15	3500	205-231	2CXE7LHOKKU0A010	£33,495
	L4H3	Relay Panel Van L4H3 35 Heavy BlueHDi 140 S&S 6-speed Manual Enterprise	1235	17	3500	217-239	2CXE7OHOKKU0A010	£34,305
	L4H2	Relay Panel Van L4H2 40 Heavy BlueHDi 180 S&S EAT8 Auto Enterprise	1955	15	4000	TBC	2CXE7MHOR1U0A010	£37,805
Window Van Enterprise	L3H2	Relay Window Van L3H2 35 BlueHDi 140 S&S 6-speed Manual Enterprise	1350	13	3500	205-231	2CXE5WHOKKU0A010	£32,685
	L4H2	Relay Window Van L4H2 40 Heavy BlueHDi 140 S&S 6-speed Manual Enterprise	1975	15	4000	TBC	2CXE7YHOKKU0A010	£34,755
Chassis Cab Enterprise	L2H1	Relay Chassis Cab L2H1 35 Heavy BlueHDi 140 S&S 6-speed Manual Enterprise	1350	-	3500	282 - 312	2CXE4GHOKKU0A010	£29,715
	L3H1	Relay Chassis Cab L3H1 35 Heavy BlueHDi 140 S&S 6-speed Manual Enterprise	1975	-	3500	282 - 312	2CXE6GHOKKU0A010	£30,255
Chassis Crew Cab Enterprise	L3H1	Relay Chassis Crew Cab L3H1 35 Heavy BlueHDi 140 S&S 6-speed Manual Enterprise	1350	-	3500	282 - 312	2CXE6YHOKKU0A010	£31,605
Floor Cab Enterprise	L3H1	Relay Floor Cab L3H1 35 Heavy BlueHDi 140 S&S 6-speed Manual Enterprise	1350	-	3500	282 - 312	2CXE6RHOKKU0A010	£30,255



All information and prices correct at time of publication, but are subject to change at any time without prior notice (which may occur as a result of matters including, but not limited to, any changes in legislation and/or any changes by the government). Please see our Prices and Specifications brochures or contact your local Citroën Retailer for the most up-to-date prices and specification details for all models. CO₂ figures above are for a standard vehicle without any additional optional equipment. The addition of optional extras could increase the certified CO₂ emission output.

* WLTP figures shown are for comparison purposes and should only be compared to the fuel consumption and CO₂ values of other vans tested to the same technical standard. The fuel consumption achieved, and CO₂ produced, in real world conditions will depend upon a number of factors including, but not limited to: the accessories fitted (pre and post registration); variations in weather; driving styles and vehicle load. The WLTP (Worldwide Harmonised Light Vehicles Test Procedure) is used to measure fuel consumption and CO₂ figures.

† All Manufacturer's Recommended Basic Prices are exclusive of V.A.T., Delivery to Retailer and Number Plates, Government First Registration Fee and Vehicle Excise Duty.

^ The Government P1VG is worked out at 35% of the Base Vehicle Price (incl. VAT) and including any discounts applied up to a maximum of £5,000.

Legal notice ELECTRIC VEHICLES:

The range and electric consumption figures mentioned comply with the WLTP test procedure, on the basis of which new vehicles are type approved from 1 September 2018. They may vary depending on actual conditions of use and on different factors such as: speed, thermal comfort on board the vehicle, driving style and outside temperature. The charging time depends in particular on the power of the charger on board the vehicle, the charging cable and the type and power of the charging station used.

NEW CITROËN E-RELAY & RELAY

Equipment

- Standard equipment
- Cost option
- Not available

	Panel Van Electric	Panel Van	Window Van Electric	Window Van	Chassis Cab Electric	Chassis Cab	Chassis Crew Cab	Floor Cab
--	--------------------	-----------	---------------------	------------	----------------------	-------------	------------------	-----------

Comfort and convenience	Panel Van Electric	Panel Van	Window Van Electric	Window Van	Chassis Cab Electric	Chassis Cab	Chassis Crew Cab	Floor Cab
Manual air-conditioning for cab area, including glovebox	-	•	-	•	-	•	•	•
Automatic air-conditioning for cab area, including glovebox	•	◦	•	◦	•	-	-	-
Rear parking sensors	•	•	•	•	•	•	•	•
Electric front windows	•	•	•	•	•	•	•	•
Twin lens door mirrors with electrically adjustable and heated upper mirror	•	•	•	•	•	•	•	•
Cruise control with variable speed limiter (Not available on Relay 40 and electric versions)	-	•	-	•	-	•	•	•
Two cup holders and mobile phone storage in centre of lower dashboard	•	•	•	•	•	•	•	•
Electric Parking Brake	•	◦	•	◦	•	-	-	-
Keyless Entry and Go	•	◦	•	◦	•	-	-	-
Electric Power Steering	•	•	•	•	•	•	•	•

Seating	Panel Van Electric	Panel Van	Window Van Electric	Window Van	Chassis Cab Electric	Chassis Cab	Chassis Crew Cab	Floor Cab
Driver's seat with height, rake, lumbar and reach adjustment	•	•	•	•	•	•	•	•
Driver's seat armrest	•	•	•	•	•	•	•	•
Dual Passenger bench seat	•	•	•	•	•	•	•	•

Technology and entertainment	Panel Van Electric	Panel Van	Window Van Electric	Window Van	Chassis Cab Electric	Chassis Cab	Chassis Crew Cab	Floor Cab
5" Colour touchscreen with DAB radio, Bluetooth® handsfree, USB socket and steering wheel mounted controls	-	•	-	•	-	•	•	•
My Citroën Play Plus featuring 10" colour touchscreen with Citroën Connect DAB radio, Bluetooth® handsfree, USB socket, bi-tuner, Apple CarPlay™, Android Auto and steering wheel mounted controls	•	◦	•	◦	•	-	-	-
7" Digital Cluster	•	◦	•	◦	•	-	-	-

Exterior Features	Panel Van Electric	Panel Van	Window Van Electric	Window Van	Chassis Cab Electric	Chassis Cab	Chassis Crew Cab	Floor Cab
Side rubbing strips	•	•	•	•	-	-	-	-
Steel wheels with centre cap	•	•	•	•	•	•	•	•

	Panel Van Electric	Panel Van	Window Van Electric	Window Van	Chassis Cab Electric	Chassis Cab	Chassis Crew Cab	Floor Cab
--	--------------------	-----------	---------------------	------------	----------------------	-------------	------------------	-----------

Exterior Features	Panel Van Electric	Panel Van	Window Van Electric	Window Van	Chassis Cab Electric	Chassis Cab	Chassis Crew Cab	Floor Cab
Twin unglazed rear doors (opening to 180°)	•	•	-	-	-	-	-	-
Twin glazed rear doors with heated windows (opening to 180°)	-	-	•	•	-	-	-	-
Nearside sliding side loading door	•	•	•	•	-	-	-	-
Glazing to row 2, 3 and nearside sliding side loading door	-	-	•	•	-	-	-	-
Aerodynamic kit: Central Spoiler, Air Guides and Active Grille Shutter	•	•	•	•	-	-	-	-

Safety and security	Panel Van Electric	Panel Van	Window Van Electric	Window Van	Chassis Cab Electric	Chassis Cab	Chassis Crew Cab	Floor Cab
Full steel bulkhead	•	•	•	•	•	•	•	•
Electronic Stability Control (ESC)	•	•	•	•	•	•	•	•
Driver's airbag	•	•	•	•	•	•	•	•
Double passenger airbag	•	•	•	•	•	•	•	•
Perimetric alarm and deadlocks	•	•	•	•	•	•	•	•
Fix and go kit	•	•	•	•	•	•	•	•
Rear visibility camera with dynamic gridlines	•	•	•	•	•	•	•	•
Tyre Pressure Monitoring System (TPMS)	•	•	•	•	•	•	•	•
Advanced Emergency Braking System (AEBS) - Pedestrian and Cyclist	•	•	•	•	•	•	•	•
Lane Support System	•	•	•	•	•	•	•	•
Traffic Sign Recognition	•	•	•	•	•	•	•	•
Driver Drowsiness Detection	•	•	•	•	•	•	•	•
Intelligent Speed Assist	•	•	•	•	•	•	•	•
Global Telematics Box	•	•	•	•	•	•	•	•
Connected Services	•	◦	•	◦	•	-	-	-

Conversions	Panel Van Electric	Panel Van	Window Van Electric	Window Van	Chassis Cab Electric	Chassis Cab	Chassis Crew Cab	Floor Cab
Electrical interface supply socket	-	-	-	-	•	•	•	•
Special order electrics - loom extension	-	-	-	-	•	•	•	•
Exclusion of the rear cab bulkhead	-	-	-	-	-	-	-	•

NEW CITROËN E-RELAY & RELAY

All Manufacturer's Recommended Basic Prices are exclusive of VAT.

Options

• Standard equipment

- Not available

		Panel Van Electric	Panel Van	Window Van Electric	Window Van	Chassis Cab	Chassis Crew Cab	Floor Cab
Doors and windows								
2nd sliding side door	PC12	£410	£410	£410	£410	-	-	-
Privacy side windows	VD10	£270	£270	£270	£270	-	-	-
270 degree opening rear doors	LL02	£320	£320	£320	£320	-	-	-
Glazed sliding side door	PC10	£230	£230	•	•	-	-	-
Sliding Glass in Sliding Doors	VG02	-	-	£320	£320	-	-	-
Wheels, tyres and suspension								
Double Leaf Rear Suspension	SE08	-	£120	-	£120	•	•	•
Full wheel hub caps	ZIAT/ ZIAV	-	£50	-	£50	£50	£50	£50
Spare wheel and winch	RS03	£180	£180	£180	£180	£180	£180	£180
Interior								
Smart tachograph	HC09	£630 ¹	£630 ¹	•	•	£630 ¹	£630 ¹	£630 ¹
Glazed bulkhead	PX09	£140	£140	£140	£140	-	-	-
Eat and Work Seat Bench	WM21	TBC	TBC	TBC	TBC	TBC	TBC	TBC
Front side air bags and window air bags	NF04	£540	£540	£540	£540	£540	£540	£540
Additional key with remote control	JA17	£50 ²	£50 ²	£50 ²	£50 ²	£50 ²	£50 ²	£50 ²
Medium fabric seat	BUFX	£30	£30	£30	£30	£30	£30	£30
Exterior								
Metallic, Thunder & Expedition paint	No code	£800	£800	£800	£800	£800	£800	£800
Fixed towing hook	AQ03	£500 ²	£500 ²	£500 ²	£500 ²	£500 ²	£500 ²	£500 ²

		Panel Van Electric	Panel Van	Window Van Electric	Window Van	Chassis Cab	Chassis Crew Cab	Floor Cab
Conversions and fleet only								
Single Passenger Airbag	NN01	£230	£230	£230	£230	£230	£230	£230
External rear-view mirrors for body size kit 2.35 m	RX05	-	-	-	-	£140	£140	-
Smart tachograph exclusion	HC08	£0	£0	£0	£0	£0	£0	£0
Single Passenger Seat	TBC	£40	£40	£40	£40	£40	£40	£40
Loose Rear Lights	SY05	-	-	-	-	£70	£70	-
Oversized rear suspensions	SE16	-	-	-	-	£270	£270	-
Exclusion speed limiter	SB15	£0	£0	£0	£0	£0	£0	£0
Armrest and lumbar adjustment for passenger's seat	WM08	£50	£50	£50	£50	£50	£50	£50
Twin Glazed Rear Doors	VC02	£300	£300	•	•	-	-	-
Capucine shelf exclusion	JO00	£0	£0	£0	£0	£0	£0	£0
Speed limiter (56 mph)	SB13	£0 ¹	£0 ¹	£0 ¹	£0 ¹	£0 ¹	£0 ¹	£0 ¹
Speed limiter (62 mph)	SB14	-	-	£0	£0	-	-	-
Special Order Electrics - Loom extension	KY06	-	-	-	-	•	•	•
Remove bulkhead	PX23	£0	£0	£0	£0	-	-	-
Heated rear window	VC02	£250	£250	•	•	£250	£250	£250

1 Standard on >4,000kg GVW (N2).

2 Available on BlueHDI only.

3 Not available on Electric versions.

4 Available on Electric versions only.

5 Available on Electric versions (N1) only.

6 Available on auto versions only

Not available on heavy versions.

NEW CITROËN E-RELAY & RELAY

All Manufacturer's Recommended Basic Prices are exclusive of VAT.

Option Packs

- Standard equipment
- Not available

Work Packs	Option Code	Panel Van Electric	Panel Van	Window Van Electric	Window Van	Chassis Cab	Chassis Crew Cab	Floor Cab
Worksite Heavy Pack: Traction plus, M+S Tyres, Double leaf rear suspension, Spare wheel winch, Spare wheel and Wheel arch mouldings	J6LK / J6LJ	-	£770	-	-	£770	£770	£770
Cargo Plus Pack: Floor protections, Full height wall protections (high level), 12V socket cargo area, 270 rear opening doors, Central led in cargo area, Handles on rear and sliding door, Rear and sliding door led in cargo area	J6CK	£1,310	£1,310	-	-	-	-	-
Conversion Pack: Transformation socket, Powerful alternator (220A), Powerful battery (105Ah)	J101	-	£230 ³	-	• ³	• ³	• ³	• ³
Conversion BEV Pack: Transformation socket, Powerful battery (105Ah)	J101	£230 ⁴	-	£230 ⁴	-	£230 ⁴	-	-

Safety Packs								
L2 Autonomous Driving BEV Pack: Double USB charging port, Wireless charger, Leather steering wheel, Chromed airvents, Driver seat carter, 230V Socket, Rain & dusk sensors and high beam recognition, Fog lights with cornering function	J6UR	£680 ⁵	-	-	-	-	-	-
L2 Autonomous Driving & Full LED Headlamps BEV Pack: Double USB charging port, Wireless charger, Leather steering wheel, Chromed airvents, Driver seat carter, 230V socket, Rain & dusk sensors and high beam recognition, Fog lights with cornering function, Full LED headlamps	J6UT	£590 ⁵	-	-	-	-	-	-
L2 Autonomous Driving Pack: L2 autonomous driving, Keyless entry and go, Electric parking brake, 230V socket, 10 radio NAV aa/cp, Automatic climate control, Double USB charging port, Wireless charger, Full digital cockpit, Chromed airvents, Leather steering wheel, Compartment under driver's seat, Driver seat carter, Medium fabric trim, Rain & dusk sensors and high beam recognition, Fog lights with cornering function	J6UV	-	£1,130 ⁶	-	-	-	-	-
L2 Autonomous Driving & Full LED Headlamps Pack: L2 autonomous driving, Keyless entry and go, Electric parking brake, 230V socket, 10 Radio NAV aa/cp, Automatic climate control, Double USB charging port, Wireless charger, Full digital cockpit, Chromed airvents, Leather steering wheel, Compartment under driver's seat, Driver seat carter, Medium fabric trim, Main & dusk sensors and high beam recognition, Fog lights with cornering function, Full LED headlamps	J6UX	-	£1,130 ⁶	-	-	-	-	-

- 1 Standard on >4,000kg GVW (N2).
 2 Available on BlueHDi only.
 3 Not available on Electric versions.
 4 Available on Electric versions only.

- 5 Available on Electric versions (N1) only.
 6 Available on auto versions only
 Not available on heavy versions.

Safety Packs								
Visibility Plus Pack: Rain and dusk sensors & High Beam Recognition, Fog lights with cornering function, Full LED headlamps	J6MV	£680	£680	£680	£680	£680	£680	£680
Visibility Plus Pack N2: Rain and dusk sensors & High Beam Recognition, Full LED headlamps	J6MW	£590	£590	£590	£590	-	-	-
City Plus Pack: Blind Spot Assist and Rear Cross Path Detection, Electric folding wing mirrors, 360 Perimeter Parking Sensors, Digital Rearview Mirror	J6S4	£1,130	£1,130	£1,130	£1,130	-	-	-
City Plus Pack N2: Blind Spot Assist and Rear Cross Path Detection, 360 Perimeter Parking Sensors, Digital Rearview Mirror	J6S5	£1,130	£1,130	£1,130	£1,130	-	-	-

Technology Packs							
Techno Plus Pack: 10" Radio NAV AA/CP, Automatic Climate Control, Double USB charging port, Connected services, Wireless charger, Full digital cockpit	J6MA	-	£1,530	-	£1,530	£1,530	£1,530
Handsfree & Socket Pack: Keyless Entry and Go, Electric parking brake, 230V Socket	J6LR	£450	£450	£450	£450	£450	£450

Style Packs							
Premium Cab Pack: Chromed airvents, Leather steering wheel, Compartment under driver's seat, Driver seat carter	BUFX	£180	£180	£180	£180	-	-
Style & Visibility Pack: Painted Bumpers, Black Skid Plates, 16" Alloy Diamond Black Wheels (Light), Rain & Dusk Sensors and High Beam Recognition, Fog Lights with Cornering Function, Full LED Headlamps	J6VU	£1,360	£1,360	£1,360	£1,360	£1,360	£1,360
Style & Visibility Pack: Painted Bumpers, Black Skid Plates, 16" Alloy Diamond Black Wheels (Heavy), Rain & Dusk Sensors and High Beam Recognition, Fog Lights with Cornering Function, Full LED Headlamps	J6VV	£1,360	£1,360	£1,360	£1,360	£1,360	£1,360

Colours and wheels

Body colours

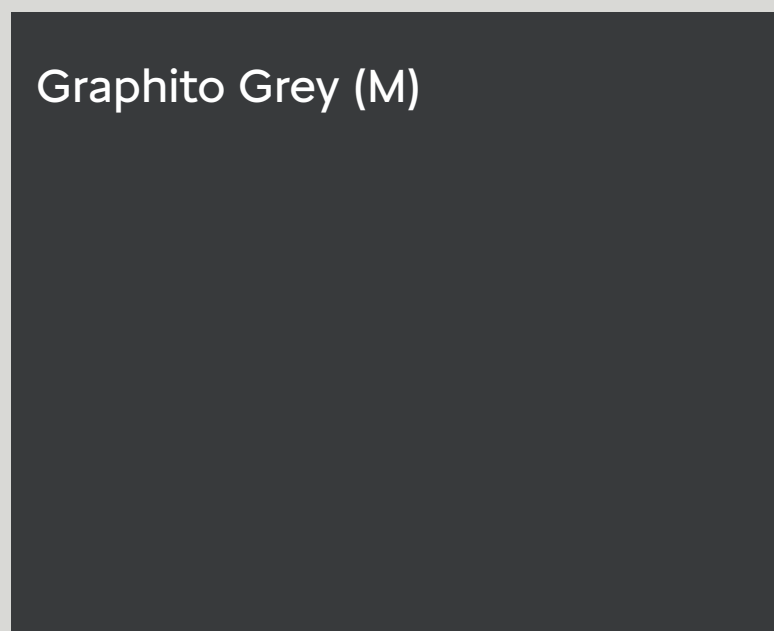
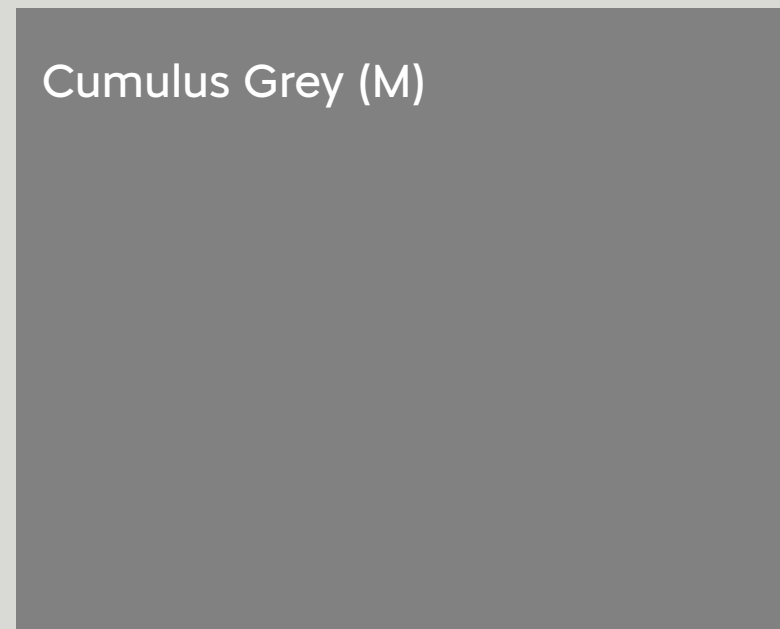
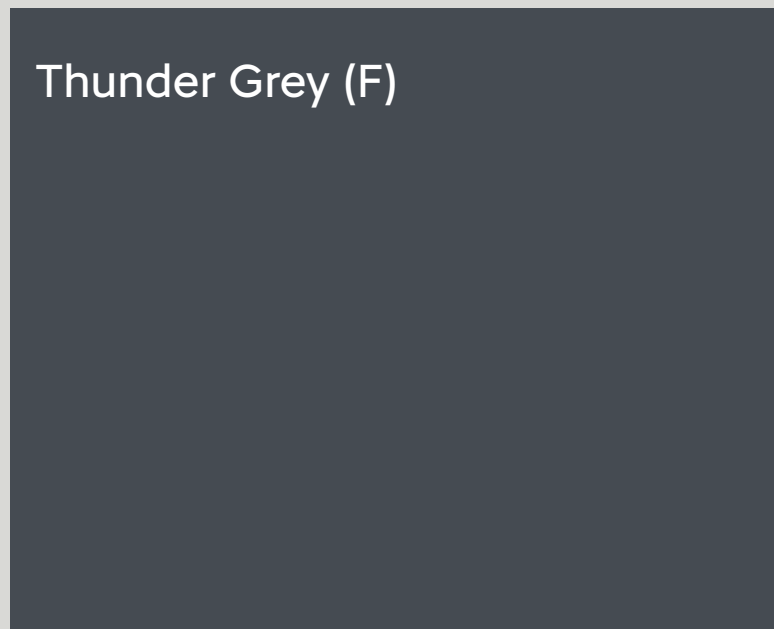
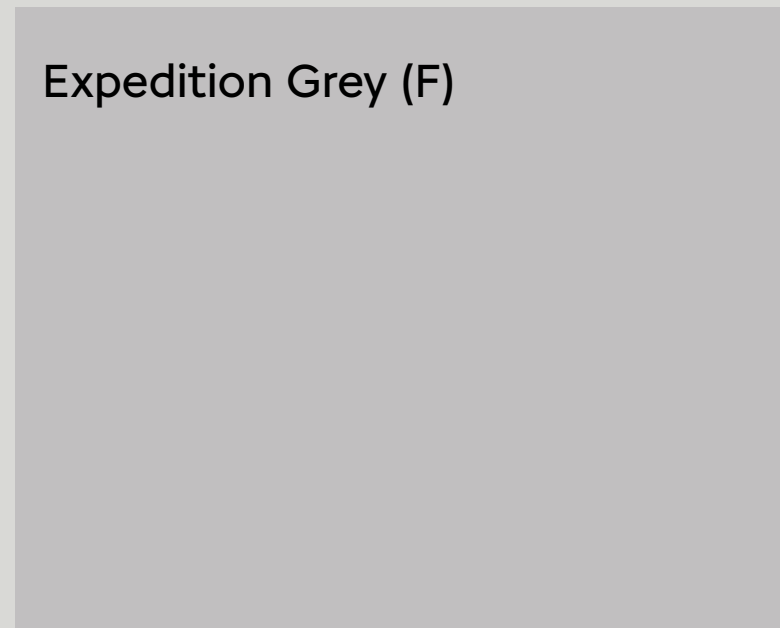

(M) Metallic
(F) Flat

Option availability varies according to version/engine/trim level.
Some options are only available as part of a pack.
Please refer to the options page for further information.

Wheels



15 inch steel wheels

Standard on 35 panel diesel vans.



16 inch steel wheels

Standard on heavy, automatic and electric vans.



15 inch wheel trim

Optional on 35 panel diesel vans.



16 inch wheel trim

Optional on heavy and automatic vans.



15 inch alloy wheels

Optional on 35 panel diesel vans.



16 inch alloy wheels

Optional on heavy, automatic and electric vans.

NEW CITROËN È-RELAY & RELAY

Interior

Interior ambience



Model shown: È-Relay.

Black cloth

Standard on all versions.

Technical

BlueHDi 140 S&S
6-speed manualBlueHDi 140 S&S
EAT8 AutomaticBlueHDi 180 S&S
EAT8 Automatic

Engine			
Capacity (cc)	2184		
Cylinders / Valves	4 / 16		
Max power CEE (kW (PS)/rpm)	103 (140) / 3500	103 (140) / 3500	132 (180) / 3500
Max torque CEE (Nm (lb/ft)/rpm)	350 (258) / 1400	380 (280) / 1400	450 (332) / 1500
Bore and stroke (mm)	TBC		
Fuel system	Diesel - High pressure turbo-charged direct injection		
Euro status	Euro 6.4		
Stop and Start system	•		
Transmission			
Gearbox	Manual	Automatic	Automatic
Number of gears	6	8	8
Further information			
Suspension	Front: Pseudo-Macpherson type with lower wishbone struts, coil springs, telescopic hydraulic dampers and anti-roll bar Rear: Longitudinal leaf springs with telescopic hydraulic dampers (reinforced twin leaf on Relay 4.0 tonne GVW versions)		
Fuel tank capacity litres (gallons)	90 (19.8)		
Adblue® tank capacity litres (gallons)	18.6		
Brakes front/ rear	Ventilated discs / discs		

Technical

110kWh Battery

Engine	
Battery	Lithium-ion 110kWh
Max Torque CEE (Nm)	410
Range (WLTP Combined @ 62mph)	Up to 261 miles
Max power CEE - kW (PS)	200Kw (272PS)

Charging time	
Single Phase 32A Wallbox (7.4kW) 0-100%	16 hours 40 minutes
Three Phase 16A Wallbox (22kW) 0-100%	11 hours 45 minutes
Rapid (DC) Charging (50 kW) 0 -80%	55 minutes

Transmission	
Gearbox	Automatic

Performance (with Driver)	
Max speed (mph)	80

Legal notice ELECTRIC VEHICLES:

The range and electric consumption figures mentioned comply with the WLTP test procedure, on the basis of which new vehicles are type approved from 1 September 2018. They may vary depending on actual conditions of use and on different factors such as : speed, thermal comfort on board the vehicle, driving style and outside temperature. The charging time depends

in particular on the power of the charger on board the vehicle, the charging cable and the type and power of the charging station used. Please contact your dealer for further information. For more information [refer to the website that each of the Brands has put in place to explain the WLTP.

CO₂ & Fuel Economy*

		WLTP CO ₂ Emissions (g/km)**		WLTP Economy Combined Litres/100km		WLTP Economy Combined mpg	
		Vehicle Low	Vehicle High	Vehicle Low	Vehicle High	Vehicle Low	Vehicle High
Panel Van Enterprise							
L2H1	Relay Panel Van L2H1 35 BlueHDi 140 S&S 6-speed Manual Enterprise	198	216	7.5	8.2	37.7	34.4
L2H2	Relay Panel Van L2H2 35 BlueHDi 140 S&S 6-speed Manual Enterprise	205	231	7.8	8.8	36.2	32.1
L2H2	Relay Panel Van L2H2 35 BlueHDi 140 S&S EAT8 Auto Enterprise	226	255	8.6	9.7	32.8	29.1
L3H2	Relay Panel Van L3H2 35 BlueHDi 140 S&S 6-speed Manual Enterprise	205	231	7.8	8.8	36.2	32.1
L3H2	Relay Panel Van L3H2 35 BlueHDi 140 S&S EAT8 Auto Enterprise	226	255	8.6	9.7	32.8	29.1
L3H3	Relay Panel Van L3H3 35 BlueHDi 140 S&S 6-speed Manual Enterprise	217	239	8.2	9.1	34.4	31.0
L3H2	Relay Panel Van L3H2 35 Heavy BlueHDi 140 S&S 6-speed Manual Enterprise	205	231	7.8	8.8	36.2	32.1
L4H2	Relay Panel Van L4H2 35 Heavy BlueHDi 140 S&S 6-speed Manual Enterprise	205	231	7.8	8.8	36.2	32.1
L4H3	Relay Panel Van L4H3 35 Heavy BlueHDi 140 S&S 6-speed Manual Enterprise	217	239	8.2	9.1	34.4	31.0
L4H2	Relay Panel Van L4H2 40 Heavy BlueHDi 180 S&S EAT8 Auto Enterprise	TBC	TBC	TBC	TBC	TBC	TBC
Window Van Enterprise							
L3H2	Relay Window Van L3H2 35 BlueHDi 140 S&S 6-speed Manual Enterprise	205	231	7.8	8.8	36.2	32.1
L4H2	Relay Window Van L4H2 40 Heavy BlueHDi 140 S&S 6-speed Manual Enterprise	TBC	TBC	TBC	TBC	TBC	TBC
Chassis Cab Enterprise							
L2H1	Relay Chassis Cab L2H1 35 Heavy BlueHDi 140 S&S 6-speed Manual Enterprise	282	312	10.8	11.9	26.2	23.7
L3H1	Relay Chassis Cab L3H1 35 Heavy BlueHDi 140 S&S 6-speed Manual Enterprise	282	312	10.8	11.9	26.2	23.7
Chassis Crew Cab Enterprise							
L3H1	Relay Chassis Crew Cab L3H1 35 Heavy BlueHDi 140 S&S 6-speed Manual Enterprise	282	312	10.8	11.9	26.2	23.7
Floor Cab Enterprise							
L3H1	Relay Floor Cab L3H1 35 Heavy BlueHDi 140 S&S 6-speed Manual Enterprise	282	312	10.8	11.9	26.2	23.7
Back to Back Enterprise							
N/A	Relay Back to Back 35 Heavy BlueHDi 140 S&S 6-speed Manual Enterprise	282	317	10.8	12.1	26.2	23.3
N/A	Relay Back to Back 40 Heavy BlueHDi 180 S&S EAT8 Auto Enterprise	305	305	11.6	11.6	24.4	24.4

* Provisional only.

** WLTP figures shown are for comparison purposes and should only be compared to the fuel consumption and CO₂ values of other vans tested to the same technical standard. The fuel consumption achieved, and

CO₂ produced, in real world conditions will depend upon a number of factors including, but not limited to: the accessories fitted (pre and post registration); variations in weather; driving styles and vehicle load. The WLTP (Worldwide Harmonised Light Vehicles Test Procedure) is used

to measure fuel consumption and CO₂ figures. The CO₂ figures display a range to reflect the highest value for the highest emitting version with all available options added, through to a minimum value to represent the lowest emitting version in standard specification.

Electric Range*

		WLTP Combined Electric Range (Miles)*		WLTP City Electric Range (Miles)*		Electric Energy Consumption (Wh/km)*	
		Vehicle Low	Vehicle High	Vehicle Low	Vehicle High	Vehicle Low	Vehicle High
Panel Van Enterprise							
L3H2	ë-Relay Panel Van L3H2 35 110kWh Enterprise	TBC	235	TBC	TBC	TBC	TBC
L3H2	ë-Relay Panel Van L3H2 40 110kWh Enterprise	TBC	263	TBC	TBC	TBC	TBC
L3H3	ë-Relay Panel Van L3H3 40 110kWh Enterprise	TBC	254	TBC	TBC	TBC	TBC
L4H2	ë-Relay Panel Van L4H2 40 110kWh Enterprise	TBC	262	TBC	TBC	TBC	TBC
L4H3	ë-Relay Panel Van L4H3 40 110kWh Enterprise	TBC	252	TBC	TBC	TBC	TBC
Window Van Enterprise							
L4H2	ë-Relay Window Van L4H2 40 110kWh Enterprise	TBC	262	TBC	TBC	TBC	TBC
Chassis Cab Enterprise							
L3H1	ë-Relay Chassis Cab L3H1 40 110kWh Enterprise	TBC	TBC	TBC	TBC	TBC	TBC



octopusenergy

Everything you need to charge

Citroën have partnered with Octopus Energy to provide everything you need for your new Citroën ë-Relay, including a tariff, charger and a solution for charging on the go making owning an electric vehicle easier and hassle-free. [Click here for more information.](#)

* The range and electric consumption figures mentioned comply with the WLTP test procedure, on the basis of which new vehicles are type approved from 1 September 2018. They may vary depending on actual conditions of use and on different factors such as : speed, thermal comfort on board the vehicle, driving style and outside temperature. The charging time depends

in particular on the power of the charger on board the vehicle, the charging cable and the type and power of the charging station used. Please contact your dealer for further information. For more information [refer to the website that each of the Brands has put in place to explain the WLTP.

Weights and loads*

		Gross Vehicle Weight (GVW)	Mass in Running Order (MIRO)	Kerb weight ⁽¹⁾	Maximum indicative payload ⁽²⁾	Max plated front axle ⁽³⁾	Max plated rear axle ⁽³⁾	Gross Train Weight (GTW)	Max. braked towing weight ⁽⁴⁾	Max. unbraked towing weight	Max. towball weight	Number of Seats
Panel Van Enterprise Edition												
L2H1	Relay Panel Van L2H1 35 BlueHDi 140 S&S 6-speed Manual Enterprise	3500	TBC	2075	1425	TBC	TBC	6000	2500	750	TBC	3
L2H2	Relay Panel Van L2H2 35 BlueHDi 140 S&S 6-speed Manual Enterprise	3500	TBC	2100	1400	TBC	TBC	6000	2500	750	TBC	3
L2H2	Relay Panel Van L2H2 35 BlueHDi 140 S&S EAT8 Auto Enterprise	3500	TBC	2160	1340	TBC	TBC	6000	2500	750	TBC	3
L3H2	è-Relay Panel Van L3H2 35 110kWh Enterprise	3500	TBC	2865	635	TBC	TBC	5900	2400	750	TBC	3
L3H2	è-Relay Panel Van L3H2 40 110kWh Enterprise	3500	TBC	2865	1385	TBC	TBC	6400	2400	750	TBC	3
L3H2	Relay Panel Van L3H2 35 BlueHDi 140 S&S 6-speed Manual Enterprise	3500	TBC	2150	1350	TBC	TBC	6000	2500	750	TBC	3
L3H2	Relay Panel Van L3H2 35 BlueHDi 140 S&S EAT8 Auto Enterprise	3500	TBC	2210	1290	TBC	TBC	6000	2500	750	TBC	3
L3H3	è-Relay Panel Van L3H3 40 110kWh Enterprise	3500	TBC	2890	1360	TBC	TBC	6400	2400	750	TBC	3
L3H3	Relay Panel Van L3H3 35 BlueHDi 140 S&S 6-speed Manual Enterprise	3500	TBC	2175	1325	TBC	TBC	6000	2500	750	TBC	3
L3H2	Relay Panel Van L3H2 35 Heavy BlueHDi 140 S&S 6-speed Manual Enterprise	3500	TBC	2190	1310	TBC	TBC	6500	3000	750	TBC	3
L4H2	è-Relay Panel Van L4H2 40 110kWh Enterprise	3500	TBC	2910	1340	TBC	TBC	6400	2400	750	TBC	3
L4H2	Relay Panel Van L4H2 35 Heavy BlueHDi 140 S&S 6-speed Manual Enterprise	3500	TBC	2235	1265	TBC	TBC	6500	3000	750	TBC	3
L4H3	è-Relay Panel Van L4H3 40 110kWh Enterprise	4000	TBC	2940	1310	TBC	TBC	6400	2400	750	TBC	3
L4H3	Relay Panel Van L4H3 35 Heavy BlueHDi 140 S&S 6-speed Manual Enterprise	3500	TBC	2265	1235	TBC	TBC	6500	3000	750	TBC	3
L4H2	Relay Panel Van L4H2 40 Heavy BlueHDi 180 S&S EAT8 Auto Enterprise	4000	TBC	2295	1955	TBC	TBC	6250	2250	750	TBC	3
Window Van Enterprise Edition												
L3H2	Relay Window Van L3H2 35 BlueHDi 140 S&S 6-speed Manual Enterprise	3500	TBC	2150	1350	TBC	TBC	6000	2400	750	TBC	3
L4H2	è-Relay Window Van L4H2 40 110kWh Enterprise	4000	TBC	2910	1340	TBC	TBC	6400	2500	750	TBC	3
L4H2	Relay Window Van L4H2 40 Heavy BlueHDi 140 S&S 6-speed Manual Enterprise	4000	TBC	2275	1975	TBC	TBC	6250	2250	750	TBC	3
Chassis Cab Enterprise												
L2H1	Relay Chassis Cab L2H1 35 Heavy BlueHDi 140 S&S 6-speed Manual Enterprise	3500	TBC	1880	1620	TBC	TBC	6500	3000	750	TBC	3
L3H1	Relay Chassis Cab L3H1 35 Heavy BlueHDi 140 S&S 6-speed Manual Enterprise	3500	TBC	1900	1600	TBC	TBC	6500	3000	750	TBC	3
Chassis Crew Cab Enterprise												
L3H1	Relay Chassis Crew Cab L3H1 35 Heavy BlueHDi 140 S&S 6-speed Manual Enterprise	3500	TBC	2115	1385	TBC	TBC	6500	3000	750	TBC	7
Floor Cab Enterprise												
L3H1	Relay Floor Cab L3H1 35 Heavy BlueHDi 140 S&S 6-speed Manual Enterprise	3500	TBC	1900	1600	TBC	TBC	6500	3000	750	TBC	3
Back to Back Enterprise												
N/A	Relay Back to Back 35 Heavy BlueHDi 140 S&S 6-speed Manual Enterprise	3500	TBC	1935	1565	TBC	TBC	6000	2500	750	TBC	3
N/A	Relay Back to Back 40 Heavy BlueHDi 180 S&S EAT8 Auto Enterprise	4000	TBC	1935	2315	TBC	TBC	6250	2250	750	TBC	3

* Provisional only.

All figures in KG unless stated.

(1) Without driver. Kerb weight is calculated for a European base specification vehicle including oil, water, lubricants, tools, spare wheel and 90% full fuel tank. Weights may change with the addition of equipment.

(2) Maximum indicative payload is calculated as the difference between GVW and kerb weight. However, due to manufacturing tolerances and differences in the specification of UK vehicles, the mass in service figure provides a closer indication of the vehicle weight and therefore enables a more realistic payload to be calculated. An individual vehicle must be weighed to establish the exact kerb weight and payload applicable to that vehicle. It is the responsibility of the driver to ensure the vehicle is operated within the legal limits.

(3) Within limits of GVW.

(4) Maximum recommended towing weight within limits of GTW.

Dimensions

Exterior Dimensions	L2		L3		L4	
	H1	H2	H2	H3	H2	H3
(mm)						
Wheelbase	3450		4035		4035	
Length	5413		5998		6363	
Height	2254	2522	2522	2760	2522	2760
Width (excluding door mirrors)	2050		2050		2050	
Front overhang	948		948		948	
Rear overhang	1015		1015		1380	
Side door width	1250		1250		1250	
Side door height	1485	1755	1755		1755	
Rear doors width	1562		1562		1562	
Rear doors height	1520	1790	1790	2030	1790	2030

Interior Dimensions	L2		L3		L4	
	H1	H2	H2	H3	H2	H3
(mm)						
Volume (m ³)	10	11.5	13	15	15	17
Load length at floor	3120		3705		4070	
Load length at mid-height with bulkhead	2914		3555		3920	
Load width (maximum)	1870		1870		1870	
Load width between wheel arches	1422		1422		1422	
Load height (maximum)	1662	1932	1932	2172	1932	2172
Load sill height	535-565		535-565		535-565	

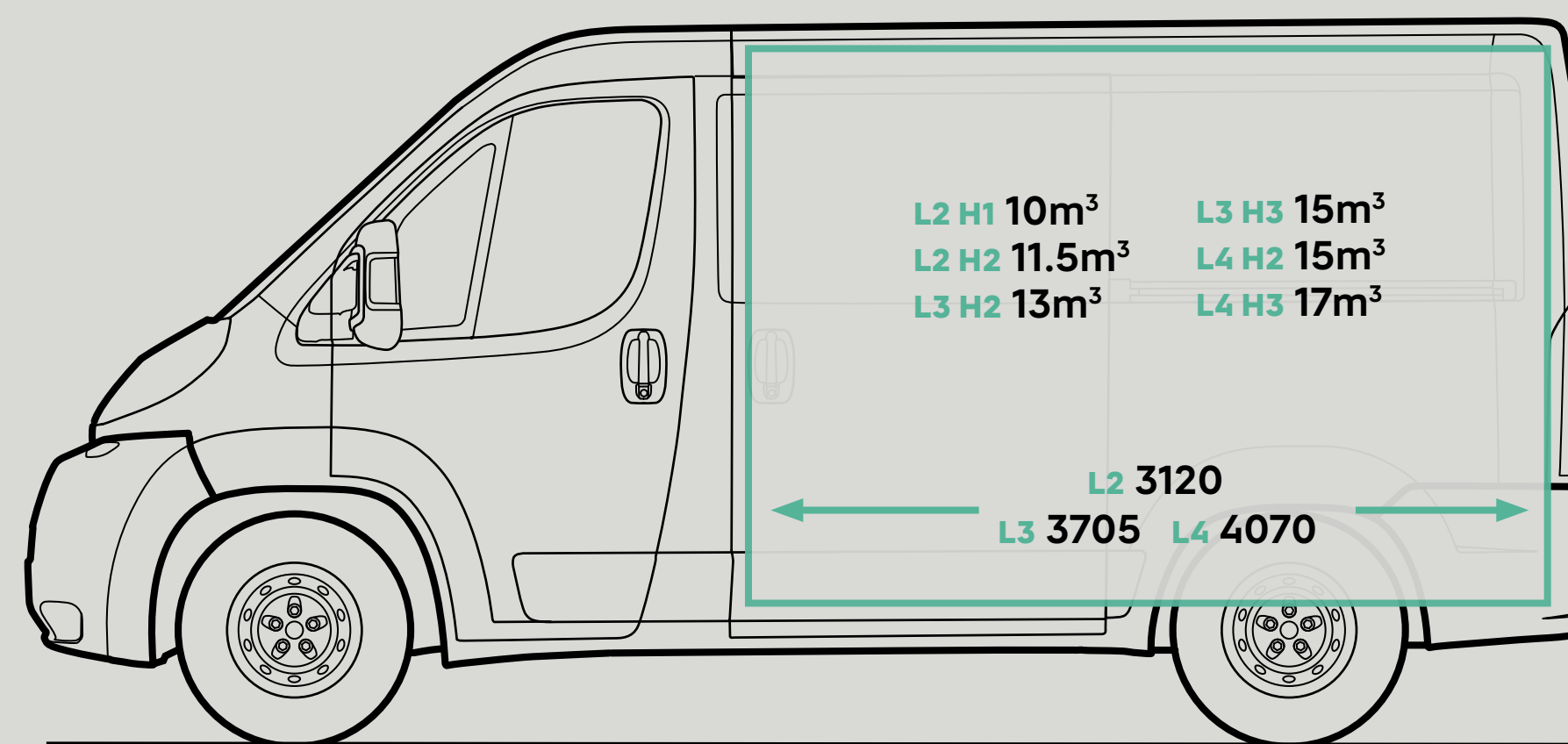
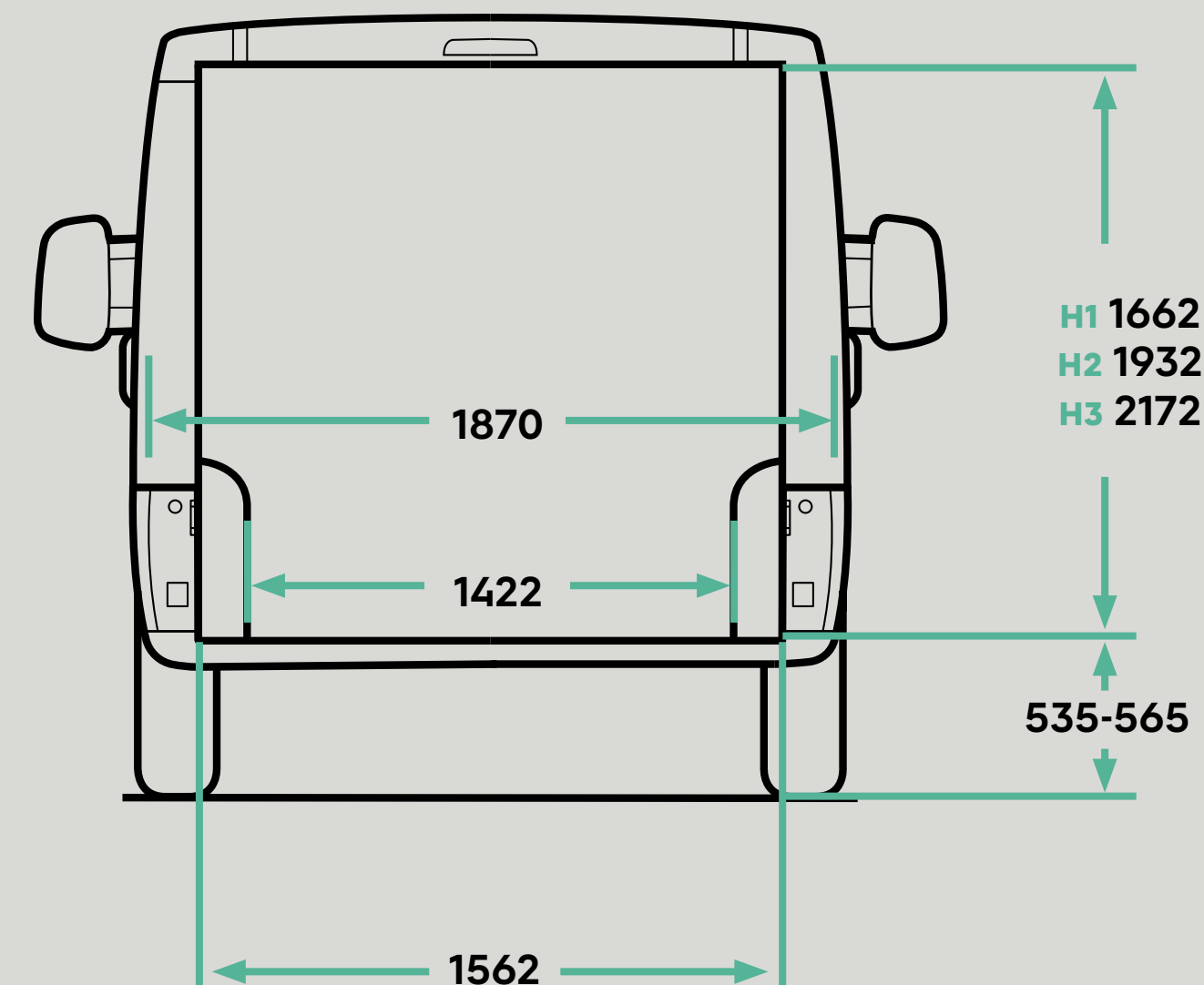

NEW CITROËN Ę-RELAY & RELAY

Citroën & You

A network of Citroën Van Retailers, Authorised Repairers and Parts Distributors are equipped and trained to meet the needs of today's Citroën customer.

Retailers can offer advice on vehicle funding; via Leasys with packages such as Contract Hire, Finance Lease or Lease Purchase for Business Users, or via Citroën Financial Services with Hire Purchase or Citroën Personal Contract Purchase for Retail buyers.

In addition Authorised Repairers have a team of technicians skilled in the care and maintenance of Citroën products.

Delivery and number plates

There is a standard charge for delivery with number plates as follows:

Citroën Berlingo & Berlingo Van, Dispatch and Relay: **£995 exc. V.A.T. (£1,194 inc. V.A.T.)**

These prices are exclusive of Vehicle Excise Duty and the Government First Registration Fee. Where delivery is not made to the customer at the Retailer's premises, a further charge may be made at the Retailer's discretion.

Vehicle Excise Duty

V.E.D. rate for all commercial vehicles up to and including 3,500kg G.V.W.: **£335**

V.E.D. rate for all commercial vehicles above 3,500kg G.V.W.: **£165**

V.E.D. is not applicable to electric versions

Vehicle conversions

Conversions of vehicles supplied by Citroën UK are carried out by independent companies to suit the needs of individual customers. In all cases, the converter company is responsible for:

- Ensuring that the converted vehicle conforms to all legislation in force at the time
- The suitability of the conversion carried out, in agreement with the customer
- The quality of design and workmanship of the conversion
- Claims under guarantee relating to the conversion

Citroën UK Ltd does not accept any liability whatsoever and howsoever incurred in respect of the works carried out by such independent companies, and customers must assure themselves of the suitability, quality and legal conformity of such conversion works.

Citroën Fleet and Business sales

All Citroën New Van Retailers are dedicated to meeting the specialist needs of both the fleet and business buyer. Their comprehensive service can include advice on important business vehicle decisions, such as alternative acquisition methods, disposal of existing vans, priority servicing and much more. In short, their expertise aims to provide a 'total transport solution' for all your fleet or business vehicle needs.

For more information on Citroën fleet and business sales please contact your local Citroën Retailer or [click here](#)

Leasys

Leasys is the proud Business Contract Hire partner of Citroën and consequently, can provide quick vehicle delivery to keep your business mobile.

Specialised in Medium to Long-Term Leasing options and Fleet Management solutions for businesses of all sizes, Leasys lead mobility by offering sustainable and innovative solutions designed around customers, for a best-in-class experience. Their team of experts can personally support you and provide dedicated consultation.

Leasys is equally owned by Stellantis and Crédit Agricole Consumer Finance and is a member of the British Vehicle Rental and Leasing Association (BVRLA).

For further information, please contact your local Citroën Retailer or [Click here](#).

Comprehensive Warranty

Every new Citroën van offers the benefit of a three year* warranty package, plus a five year anti-perforation** warranty and a two year paint warranty.

In addition, the Ę-Berlingo, Ę-Dispatch and Ę-Relay offer a manufacturer's battery warranty of eight years/100,000 miles up to 70% charging capacity.

* Two years' unlimited mileage manufacturer's warranty. No-fee customer option of one year's Retailer provided warranty, only on vehicles sourced from Citroën UK Limited. Note: Retailer provided warranty is limited to 100,000 miles for all commercial vehicles including motorhomes and other converted vehicles.

** Against all internal to external perforation to bodywork or underbody on condition the van undergoes an inspection by a Citroën franchised Retailer on its second and fourth anniversaries.

Citroën Assistance

In response to a free telephone call in the UK, Citroën Assistance brings rapid expert roadside assistance to you in an emergency.

It comes free of charge for a full year, from date of vehicle registration, and operates 24 hours a day in all parts of the UK and Europe. Services include nationwide recovery for both van and passengers, a home call service, replacement vehicle, hotel accommodation and vehicle storage if required. You can also purchase additional Citroën Assistance via your local Citroën Retailer at any time. Please note, Citroën Assistance only applies to incidents covered by the new vehicle warranty, and excludes non-vehicle faults, such as running out of fuel, mis-fuelling, loss of keys, lock-ins, road traffic accidents and punctures/wheel changes.

Ę-Berlingo, Ę-Dispatch and Ę-Relay comes with a free of charge three year Citroën Assistance starting from the date of registration.

For more details please [click here](#)

Servicing

Available up to one year from your vehicle's registration date, but before its first chargeable service, a Citroën Servicing package enables you to pay in advance for:

- Scheduled Servicing†
- Annual Service(s)† for vehicles with a two year service plan
- Brake Fluid Replacement†

This package can be personalised depending on your needs, with options ranging from 12 to 60 months and 10,000 to 100,000 miles.

† As outlined in your vehicle's Maintenance & Warranty Guide.

Maintenance

For a single fee or low monthly payments, you can put yourself in control of your maintenance costs. Depending on your needs, you can choose from a package that covers you between 12 and 48 months and between 10,000 and 150,000 miles and provides you with:

- Scheduled Servicing†
- Periodic Maintenance†
- Wear and Tear Cover – The replacement of friction materials such as brake pads, discs, wiper blades, clutch and other such items needed to keep you and your vehicle on the move
- Citroën Assistance, provided by the AA, includes: Roadside & At Home Assistance, Recovery, Onward Travel and European Cover

- MOT test fees

Why not add the following option to your chosen package:

- Replacement of worn tyres, including wheel balancing (includes puncture repairs)
- Replacement vehicle whilst yours is being serviced or MOT'd

Rest assured that all Maintenance and Servicing work will be carried out by qualified Citroën Technicians at any Citroën Authorised Repairer within the UK, using only Citroën Original Equipment and Approved Parts.

For further information, please contact your Citroën Retailer.

Citroën Motor Insurance

Citroën Insurance has been designed specifically for our vehicles. You don't just get repairs you get Citroën expertise, service, quality and parts. You see, where other insurers see a vehicle, we see a Citroën.

So, when the time comes to renew your insurance cover, call Citroën Insurance on 0370 024 2725. (Lines open 8am-8pm weekdays, 9am-5pm Saturdays)

Alternatively, visit www.citroen.co.uk for more information or to apply online.

Citroën Insurance policies are underwritten by U K Insurance Limited, Registered office: The Wharf, Neville Street, Leeds, LS1 4AZ. Registered in England & Wales No. 1179980. U K Insurance Limited is authorised by the Prudential Regulation Authority and regulated by the Financial Conduct Authority and the Prudential Regulation Authority. Citroën Insurance is a trading style of PSA Finance UK Limited (company registration number: 01024322) having its registered office at 61 London Road, Redhill, Surrey, RH1 1QA.

Internet

[Click here](#) to visit the Citroën Website for full information on all Citroën products and offers available in the UK, together with details of our environmental and recycling policies. Or [click here](#) to contact Citroën directly. Alternatively, for further information, please contact your Citroën Retailer.

Citroën Connected Services

Vehicles equipped with the Citroën Connect box have an embedded SIM card.

This means that as well as safety features, Citroën drivers can subscribe to a range of connected services:

- Real Time Traffic and Speedcam alerts: with live data to enhance the Citroën Connect Nav system
- Remote access to lock or unlock the vehicle's doors from a smartphone
- E-remote Control: remote management of electric vehicle charging and temperature
- And much more!

Service availability depends on the hardware fitted on each vehicle. For more information [click here](#).

CITROËN



To find out more
visit citroen.co.uk



To find out more about Motability,
please contact your local retailer or
[click here](#)

Citroën UK Ltd, Pinley House, 2 Sunbeam Way, Coventry CV3 1ND.

NOTE: Every endeavour has been made to ensure that the information, including prices, contained in this leaflet was accurate at the time of publishing June 2024. The Company however, reserves the right, whilst preserving the essential characteristics of the models described, to introduce at any time modifications, changes of details, equipment or accessories as may be considered necessary to improve the models described or for any other reason of a constructional or operational nature.

Designed and produced by www.weareacuity.com

CITROËN PREFERRED TotalEnergies